



Subsea Cable and Umbilical Accessories



A subsidiary of TT electronics plc



WT Henley Limited

Bespoke Engineering Solutions

The name W T Henley has been synonymous with Subsea telegraphy and power distribution since the company was founded in 1837.

We have an impressive track record of supplying many of the world's largest Utilities and Oil and Gas Majors with specialised Subsea cable accessories, these being essential to enable the

installation and maintenance of Subsea power and communication distribution systems.

In more recent years, W T Henley has been in the vanguard of development to support the rapidly growing market associated with offshore power generation from renewable resources.

Special Products and Jointing Services.

Our product range includes specially designed pulling heads, hang off's and repair joints to ensure that torsionally balanced or uni directionally armoured (coilable) cables safely reach their destination on or below the ocean floor such that the system can be connected and maintained with confidence.

Other products which can be supplied to

complement our in house range of accessories include Power and Optical Fibre Termination boxes in hazardous areas, dry mateable connectors, 'J' tube bungs, bend stiffeners and cable repair joints.

W T Henley can also provide fully trained and qualified Jointing Technicians and Test Engineers to assist in the installation of our accessories and system commissioning.



First with Quality and Reliability

Our commitment to quality and customer service has helped to ensure that W T Henley is a name that our customers the world over have come to depend on.

Steadfast attention to detail, guarantees that all our products from design through to final manufacture and supply will conform to the appropriate international or customer specification.

W T Henley is fully audited and approved to ISO 9001: 2000 under certificate number 11261. We can draw on a wealth of knowledge and experience in the design of Subsea cable accessories and the full backing of our team of design engineers further complements this.

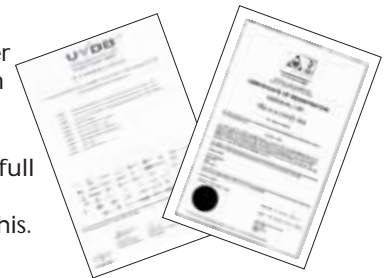

Typical Products

Pulling head

To enable the safe installation of the cable to the platform or riser deck, W T Henley have designed a pulling head which connects directly onto the cable armour layer(s). This ensures that all mechanical forces associated with pulling the cable via the 'J' or 'I' tube are borne by the armour with minimal transference of strain to the internal cable.

Hang off

Once installed and at the top of the 'J' tube the cable is mechanically secured by the installation of a hang off clamp. The cable armour is terminated within a clamping arrangement which ensures the mechanical stresses expected to occur during service life are safely borne by the cable structure. Where appropriate, Cable hang off's can be supplied combining core breakout and/or jointing to the topside cable. Pre-fitted and post fitted systems can be supplied

Repair Joint

For the repair and maintenance of Submarine Transmission and Distribution systems,

W T Henley have designed and developed a family of repair joints. These are for polymeric or paper insulated power (up to 36kV) and composite power / optical fibre cables, capable of enduring the extremes of mechanical and electrical stresses encountered during system installation and operation.

Other Accessories

In addition, W T Henley can provide the full range of accessories required to enable the successful installation and operation of Electrical or Composite Electrical/Optical Submarine Cables and Umbilicals including...

- Beach Clamps
- Beach/Transition Joints
- Bend Stiffeners
- Bend Restrictors

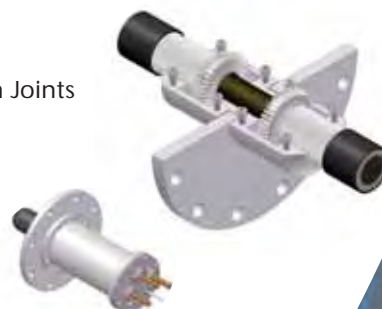

From Utilities via **Offshore Oil** and Gas to Renewable Power

Utilities

For over 50 years WT Henley have been designing and supplying accessories for this demanding market worldwide.

The most onerous sea bed and tidal conditions are often encountered close to shore. WT Henley's Submarine Cable accessories have demonstrated a capability to maintain operation over many years in these demanding environments.

Oil and Gas Recovery

The interconnection of offshore Oil and Gas platforms for both power and communications / data has enabled the economic extension of operating life in many 100's of fields worldwide. WT Henley are proud to have played our part in this technology via the design and development of the specialist installation and maintenance accessories essential for the operation of these interconnections.

Renewable Energy

The United Kingdom is Europe's windiest country. As part of the British Government's commitment to reduce production of greenhouse gases, offshore Windfarms are being developed around the coast.

W T Henley is pleased to have been responsible for the design, manufacture and supply of Subsea cable accessories, for the major developments at North Hoyle, Scroby Sands and Kentish Flats.

In addition, we have designed and supplied equipment for the prototype wave energy convertor, constructed at the UK Marine Energy test centre in Orkney (Scotland).



Our impressive track record

Over the last 50 years W T Henley has supplied a wide range of repair joints, hang off's, pulling heads and other specialist installation accessories including the following projects, updated to include the more recent Windfarm and Iran and Brunei contracts:-

Recent projects where W T Henley Subsea Cable Accessories have been used

Year	Project	Year	Project
1996	Shell (UK) Gannett Project	2005	Kentish Flats Windfarm
1996	ESB Ireland - Island Links	2005	Shell Brunei, Champion West 3 Project 6.6kV with Fibre
1997	Ofon, Elf Nigeria5,	2005	Amid Engineering, Salman Project (NIOC) 11kV with Fibre
1997	Shell (UK) Galleon Project Phase 2	2005	Scottish & Southern Energy 33kV paper
1997	Sirri A and E, Total Oil (Sirri)/NIOC	2006	Vestas/Ballast Nedam, Egmond Windfarm 33kV with Fibre
1998	NASR PP02 and PP04, Total Oil (Sirri)/NIOC	2006	JDR Cables, Beatrice Windfarm Project 33kV with Control Cores + fibre
1998	Scottish Hydro Pentland Crossing	2007	Tratos Cavi, LNG platform Adriatic Optic Fibre Cable
1999	Shell Nigeria, ODIDI project	2007	Scottish & Southern Energy 33kV paper - Polymeric
1999	Shell Nigeria, ODIDI project	2007	BP (UK) Amethyst Platform Repairs 11kV with Fibre
2000	Amec/Border Wind, Blyth Windfarm	2007	NSW Cables LV with Control Cores + Fibre
2000	Shell (UK) Skiff		
2000	Shell (UK) Brigantine		
2001	Scottish and Southern Energy, Mull-Coll		
2001	Shell (UK) Brigantine II		
2001	Shell (UK) Auk-Fulmar		
2001	Shell (UK) Brent-Dunlin		
2001	KST/KEPCo, Choyakdo - Saengildo, Korea		
2002	Shell (UK) Brent A-Brent B		
2002	Shell Brunei Champion West Project		
2002	Shell Brunei Egret Project		
2002	Shell Brunei Iron Duke Project		
2003	Southern Electric UK Orkney Wave Energy		
2003	Otronix, Jinhae (Korean Navy)		
2003	Mayflower Energy, North Hoyle Windfarm		
2003	Vestas-Celtic, Scroby Sands Windfarm		
2004	Otronix,Gukhwado Island KTS/KEPCO		



W T Henley Limited

WT Henley Limited

Silver Key, Church Manorway
Belvedere, Erith, Kent DA8 1EX, England

Telephone: +44 (0) 1322 444500

Facsimile: +44 (0) 1322 444502

Email: sales@wt-henley.com

Website: www.wt-henley.com

The equipment detailed in this publication, should only be installed by a competent person.
Due to continuous product development, prices and specifications are subject to change without prior notice.
(c) W T Henley Limited

