

AB Connectors

Application

Continuity bonding of metallic cable armouring

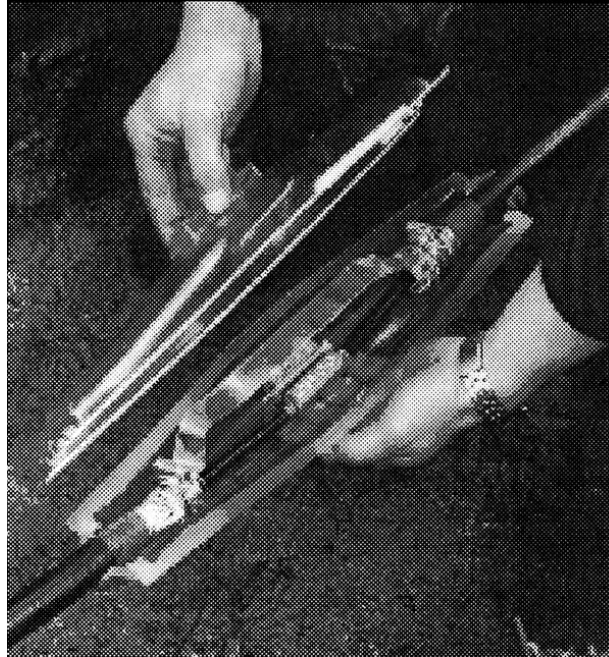

Introduction

The Sicame armour bonding systems were developed in collaboration with the United Kingdom electricity supply industry to provide adequate electrical continuity across joints in metallic armoured cables.

The Sicame systems, strictly applied, satisfy the IEE Wiring Regulations, 15th Edition, 1981, which require the electrical continuity of metallic cable armouring to be fully maintained. They are used extensively by public utilities and electrical contractors in distribution networks, and for terminations on switchgear, transformers and other apparatus.

They are widely adaptable, and suitable for application to either steel tape or steel wire armoured cables. The components are available in comprehensive size ranges, to meet the requirements of a wide variety of joints, and they can be supplied individually, or collectively to agreed specifications for particular joints.

There are two systems, which differ principally in the method employed to secure the bond; the tension strap system, recommended for larger distribution cables, and the worm-drive clip system, which is generally more suitable for smaller distribution and control cables.

Sicame Electrical Developments Ltd. offer a service in establishing suitable specifications covered by individual references, for mutual convenience.

AB Connectors

The Sicame Systems

The Sicame Armour Bonding Systems are reliable and convenient methods of cross-bonding breaks in the metallic armour of cables, by means of a bond comprised of one or more tinned copper strips of standard size, which is secured to the exposed armour at each end of the break in order to maintain electrical continuity. The choice of components is influenced by two broadly separate considerations.

Physical Considerations

- a. Cable descriptions and dimensions, which determine the method of fixing and the size of the components to secure the bond.
- b. Joint configuration, which determines the number of continuity bond connections required, and the length of the bonds.

Electrical Considerations

- a. Jointing techniques, which can influence the choice of certain components for securing the bond.
- b. The required current carrying capacity of the bond, which determines the number of tinned copper strips required to give an electrically adequate total cross-sectional area.

The two systems of bonding are:

- a. By a tension strap, usually employed for larger distribution cables.
- b. By a worm-drive clip, intended primarily for use on smaller distribution and control cables.

The systems differ only in the method of applying circumferential tension to secure the bond to the armour. Common to both is a compression ring placed under the armour (which serves the dual purpose of providing a firm base on which to develop a good electrical contact, and preventing damage to the core bedding and conductor insulation) and a tinned copper bedding braid passed around the outside of the armour to improve the electrical transition between the cable armour and the bond.

The components for each type consist of: -

(a) Tension Strap Type

- 1 interlocking steel split compression ring
- 1 length of tinned copper bedding braid
- 1 buckle - various types for different applications - see components list page 4.05.
- 1 steel tension strap.

The strap is tensioned around the armour by means of a special tool ref. JTS/1; detailed instructions on its use appear on pages 4.14 and 4.15.

(b) Worm-drive Clip Type

- 1 interlocking, or solid, steel split compression ring
- 1 length of tinned copper bedding braid
- 1 worm-drive clip - screwdriver fixing.

The tinned copper strips are selected independently according to the requirements of the joint under assembly. See page 4.19

AB Connectors

Selecting the Components

The permutations of metallic armoured cables with those of joint configuration are considerable, and with certain exceptions (see below) it is impracticable to offer from stock preselected packs of bonding components for every foreseeable jointing situation. It is necessary, therefore, to build up the components required for each joint specification from the component tables on page 4.04.

The following details are essential to making a correct selection:

	DETAIL	OBJECTIVE
Cables	Under-armour diameter mains A	Size of compression rings
	Under-armour diameter mains B	Length of tension strap
	Under-armour diameter branch/service	Number of tinner copper strips
	Required current-carrying capacity	
Joints	* Number of bond connections	Number of connection components
	Span length of joints	Length of tinner copper strips
	* Configuration	
	Jointing methods where alternative components are used.	Type of Buckle

* The number of bond connections will vary with the joint configuration; a completed bond may incorporate one or more bond connections. For example, a termination joint will require only one set of connection components, a straight-through joint two sets, and a branch joint three or more.

Sweated, Plumbed or Bolted Connections

The Sicame armour bonding systems offer a comprehensive technique for the cross bonding of metallic cable armour, but Sicame Electrical Developments acknowledge that the systems can be adapted for other types of connections and cross-bonding materials. Accordingly, a range of alternative buckles is available, which after securing to the cable armour by means of a tension strap, are suitable for either sweated, plumbed or bolted connections of the bond. These are detailed on page 4.05.

CONNECTION KITS

For armoured cables manufactured to BS 6346 (1977), as the most popular type of cable used in industrial installations, it has been possible to standardise the components necessary to secure the bond in the form of a kit, for both tension strap and worm-drive clip fixing.

It is important to note that a kit represents a single bond connection, to one armour termination only. A completed bond may incorporate one or more kits.

Tables for these kits appear on pages 4.08 and 4.10.

AB Connectors

Component Tables With Illustrations

Steel Compression Rings	Part No.	Inside Dia.		Wt. per 100 (Kgs)
		mm	ins	
Interlocking Split Type	226	19	0.75	2.0
	227	22	0.88	2/9
	228	25	1.0	3.4
	229	29	1.13	3.8
	230	32	1.25	4.0
	231	35	1.38	7.2
	232	38	1.5	7.8
	233	41	1.63	8.4
	234	44	1.75	9.3
	235	48	1.88	9.7
	236	51	2.0	10.4
	237	54	2.13	11.1
	238	57	2.25	11.7
	239	60	2.38	12.4
	240	63.5	2.5	13.1
	242	70	2.75	14.3
244	76	3.0	15.5	
245	83	3.25	17.0	

Compression Rings

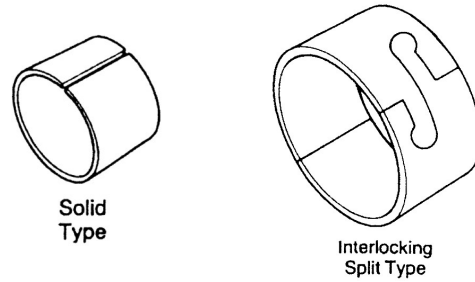

Steel Compression Rings	Part No.	Inside Dia.		Wt. per 100 (Kgs)
		mm	ins	
Solid Type	63	13	0.5	1.1
	64	16	0.63	1.3
	65	19	0.75	1.6
	66	22	0.88	1.8
	67	25	1.0	2.0
	68	29	1.13	2.3

Tension Straps

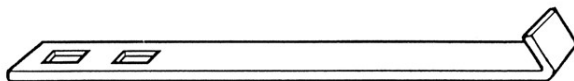

Tinned Mild Steel Tension Straps	Part No.	S.W.	Length		Wt. per 100 (Kgs.)
			mm	ins	
Mains	3	16	248	9.75	6.2
	2	16	352	13.88	8.8
	2a	14	352	13.88	11.0
	637	16	476	18.75	10.7
Service	5a	16	476	18.75	2.7
	910	18	330	13.0	4.2

AB Connectors

Component Tables With Illustrations

Buckles

Tinned Tension Strap Buckles	Part No.	S.W.	Material	Wt. per 100 (Kgs.)
Mains	594	14	Mild Steel	1.8
Service	278	16	Mild Steel	0.8
	597	14	Copper	1.0

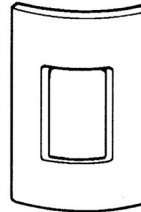

278/597

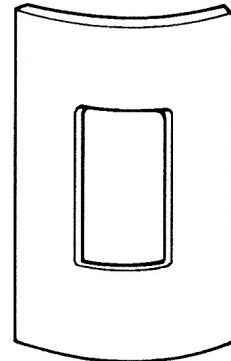

594

Alternative Buckles

Tinned Tension Strap Buckles	Part No.	S.W.G.	Material	Application	Wt. per 100 (Kgs.)
Mains	315	12	Copper	For connections at 90° to cable	6.6
	317	14	Mid Steel	For connections in line with cable	3.8
	318	12	Copper	For connections in line with cable	5.5
	342	14	Steel	Ferrule type for stranded bonds	3.7
	555	14	Steel	Bolted type (3/8" - M10 bolt)	2.6
	018	12	Copper	Bolted type (3/8" - M10 bolt)	9.6
Service	340	16	Mid Steel	For flat strip or stranded bonds	1.2
	341	16	Copper	For flat strip or stranded bonds	1.7

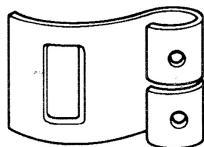

342

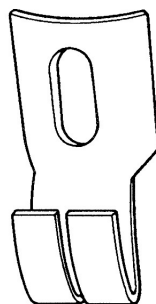

315



340/341

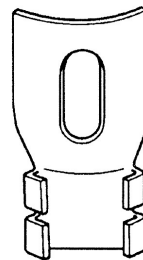

317/318

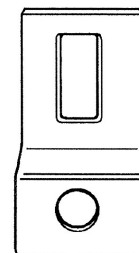

555

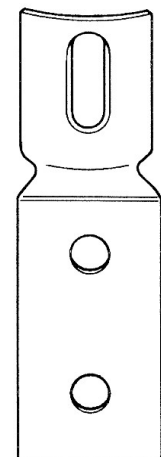

018

AB Connectors

Component Tables With Illustrations

Tinned Copper Strips

Tinned Copper Strip 18 mm ² c.s.a.	Part No.	Length		Wt. per 100 (Kgs)
		mm	ins	
Tension Strap System	281	216	8.5	3.4
	283	305	12	4.7
	285	381	15	6.2
	289	457	18	7.1
	290	533	21	8.8
	291	610	24	9.4
	292	686	27	11.0
	293	762	30	12.0
	294	838	33	13.0
	295	914	36	14.5
	296	991	39	16.1
	297	1067	42	16.4
	298	1143	45	17.6
	300	1295	51	19.0
301	1372	54	22.0	

Tinned Copper Strip 18 mm ² c.s.a.	Part No.	Length		Wt. per 100 (Kgs)
		mm	ins	
Worm Drive Clip System	1/020	300	11.75	5.3
	1/021	500	19.75	7.6
	1/022	750	29.5	12.0
	1/023	1000	39.13	15.5

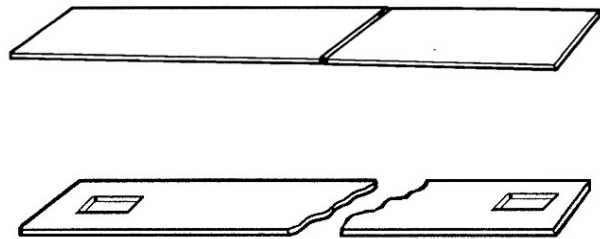

- Worm-drive clips are standard products which can be supplied if required.
- Other types of bonds eg. tinned copper braid or P.V.C. insulated cable can also be supplied.
- Tinned copper bedding braid is supplied either in coils or cut to length as required.

Tinned Copper Braid

Part No.	Width		Coil Length (metres)
	mm	ins	
004	11	0.44	20
310	26	1	10

AB Connectors

The Tension Strap System

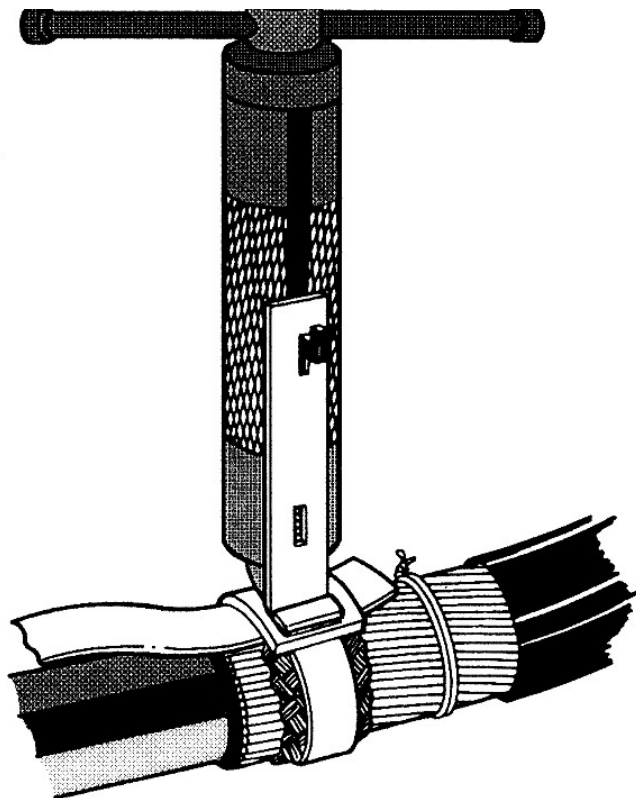
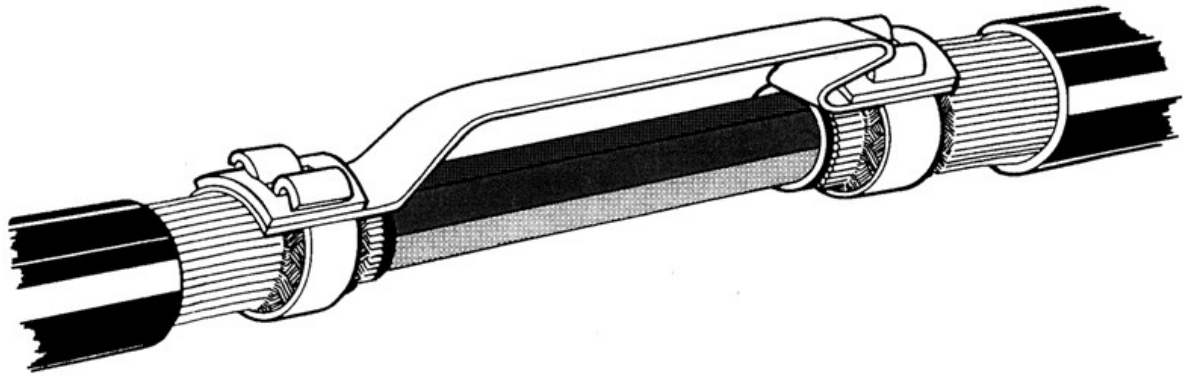

The basic components

- 1 interlocking split compression ring
- 1 steel tension strap
- 1 steel buckle
- 1 piece tinned copper braid

The tension strap is fitted with the aid of special tool Ref. JTS/1 (Detailed instructions appear on pages 4.14 and 4.15).

The components of the actual cross-bond are selected independently, these being subject to the dimensions of the particular joint under assembly, and the length and number should be stated when ordering. See page 4.19.

The tension strap system has been independently tested and is widely used within the United Kingdom electricity supply industry. (Test Report No. AB20 refers).

AB Connectors

Connection kits for P.V.C. Insulated S.W.A. Cables to BS 6346.

Product Code AB/HBT

Nominal C.s.a. of Phase Conductor	4 CORE		3 CORE		2 CORE	
	Solid	Stranded	Solid	Stranded	Solid	Stranded
mm ²						
16	HBT/1	HBT/1	HBT/1	HBT/1	HBT/1	HBT/1
25	HBT/2	HBT/2	HBT/1	HBT/2	HBT/1	HBT/1
35	HBT/2	HBT/2	HBT/1	HBT/2	HBT/1	HBT/1
50	HBT/2	HBT/3	HBT/2	HBT/3	HBT/1	HBT/2
70	HBT/3	HBT/3	HBT/2	HBT/3	HBT/2	HBT/2
95	HBT/4	HBT/4	HBT/3	HBT/3	HBT/2	HBT/3
120	HBT/4	HBT/5	HBT/3	HBT/4	HBT/3	HBT/3
150	HBT/5	HBT/5	HBT/4	HBT/4	HBT/3	HBT/3
185	HBT/5	HBT/6	HBT/4	HBT/5	HBT/4	HBT/4
240	HBT/6	HBT/7	HBT/5	HBT/6	HBT/5	HBT/5
300	HBT/7	HBT/8	HBT/6	HBT/6	HBT/6	HBT/6

HEPBOND - DIMENSIONS OF COMPRESSION RING AND COPPER BRAID COMPONENTS					
Kit Ref.	Ring Internal Dia. (mm)	Braid Length (mm)	Kit Ref.	Ring Internal Dia. (mm)	Braid Length (mm)
HBT/1	19	100	HBT/5	44.0	210
HBT/2	25	150	HBT/6	51.0	230
HBT/3	32	170	HBT/7	57.0	250
HBT/4	38	190	HBT/8	63.5	280

AB Connectors

The Worm Drive Clip System

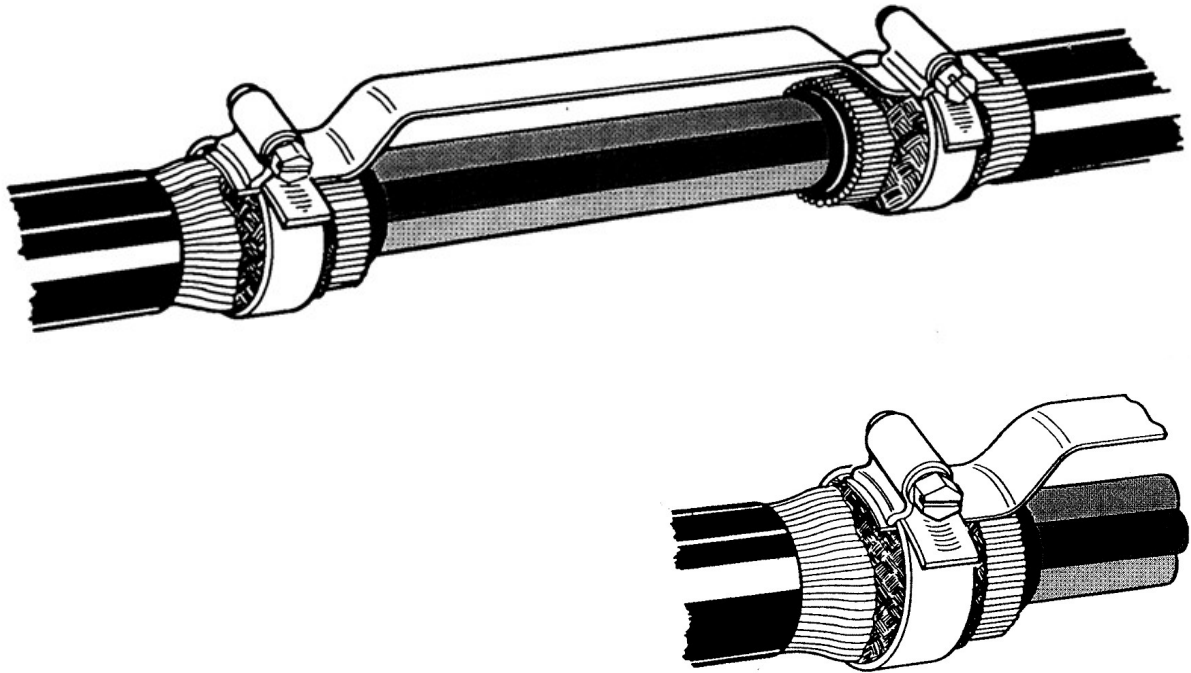

The basic components

- 1 interlocking split compression ring
- 1 worm-drive clip
- 1 piece tinned copper braid.

The components of the actual cross-bonds are selected independently, these being subject to the dimension of the particular joint under assembly, and the length and number should be stated when ordering. See page 4.19.

In view of the subjective element present in the tightening of the worm-drive clip, and source variations in the clip itself where local purchasing may be preferred, independent testing of the worm-drive clip system is not possible, and no test data is therefore available.

AB Connectors

Connection kits for P.V.C. Insulated S.W.A. Cables to BS 6346.

Product Code AB/HBW

Nominal C.s.a. of Phase Conductor	4 CORE		3 CORE		2 CORE	
	Solid	Stranded	Solid	Stranded	Solid	Stranded
mm ²						
16	HBW/1	HBW/1	HBW/1	HBW/1	HBW/1	HBW/1
25	HBW/2	HBW/2	HBW/1	HBW/2	HBW/1	HBW/1
35	HBW/2	HBW/2	HBW/1	HBW/2	HBW/1	HBW/1
50	HBW/2	HBW/3	HBW/2	HBW/3	HBW/1	HBW/2
70	HBW/3	HBW/3	HBW/2	HBW/3	HBW/2	HBW/2
95	HBW/4	HBW/4	HBW/3	HBW/3	HBW/2	HBW/3
120	HBW/4	HBW/5	HBW/3	HBW/4	HBW/3	HBW/3
150	HBW/5	HBW/5	HBW/4	HBW/4	HBW/3	HBW/3
185	HBW/5	HBW/6	HBW/4	HBW/5	HBW/4	HBW/4
240	HBW/6	HBW/7	HBW/5	HBW/6	HBW/5	HBW/5
300	HBW/7	HBW/8	HBW/6	HBW/6	HBW/6	HBW/6

HEPBOND - DIMENSIONS OF COMPRESSION RING AND COPPER BRAID COMPONENTS					
Kit Ref.	Ring Internal Dia. (mm)	Braid Length (mm)	Kit Ref.	Ring Internal Dia. (mm)	Braid Length (mm)
HBW/1	19	100	HBW/5	44.0	210
HBW/2	25	150	HBW/6	51.0	230
HBW/3	32	170	HBW/7	57.0	250
HBW/4	38	190	HBW/8	63.5	280

AB Connectors

Illustrations—Typical Assembly Procedure

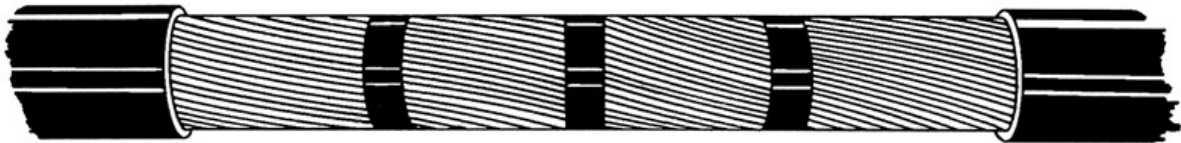

1. Remove the cable oversheath in accordance with the jointing instructions ensuring that there is sufficient length to allow the assembly of the joint, armour bond and temporary continuity connection. Apply temporary binders of P.V.C. tape to secure armours immediately outside the positions of the armour terminations.

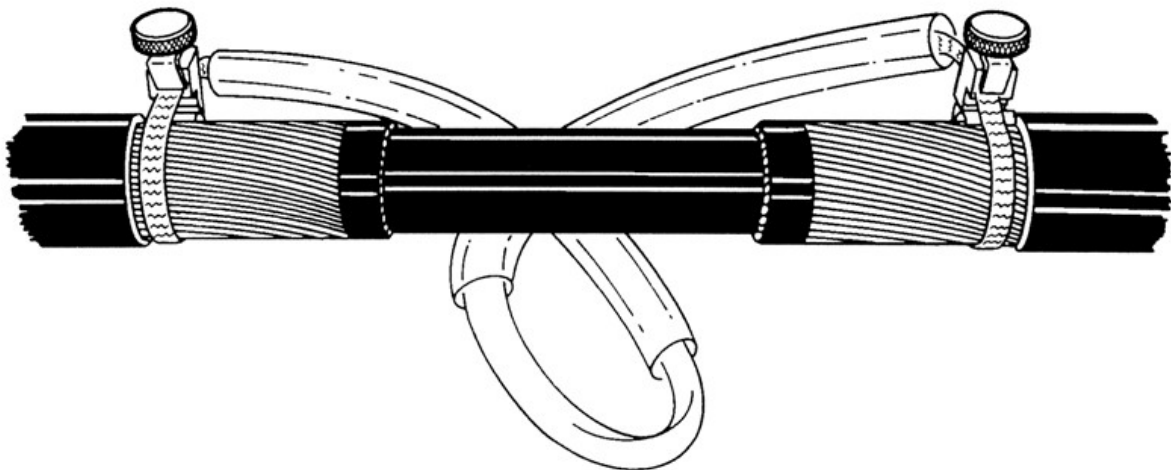

2. Before any of the armouring is removed it is recommended that a Hepworth Temporary Continuity Connector is applied to provide electrical continuity across the armour during the jointing procedure.

AB Connectors

Illustrations—Typical Assembly Procedure

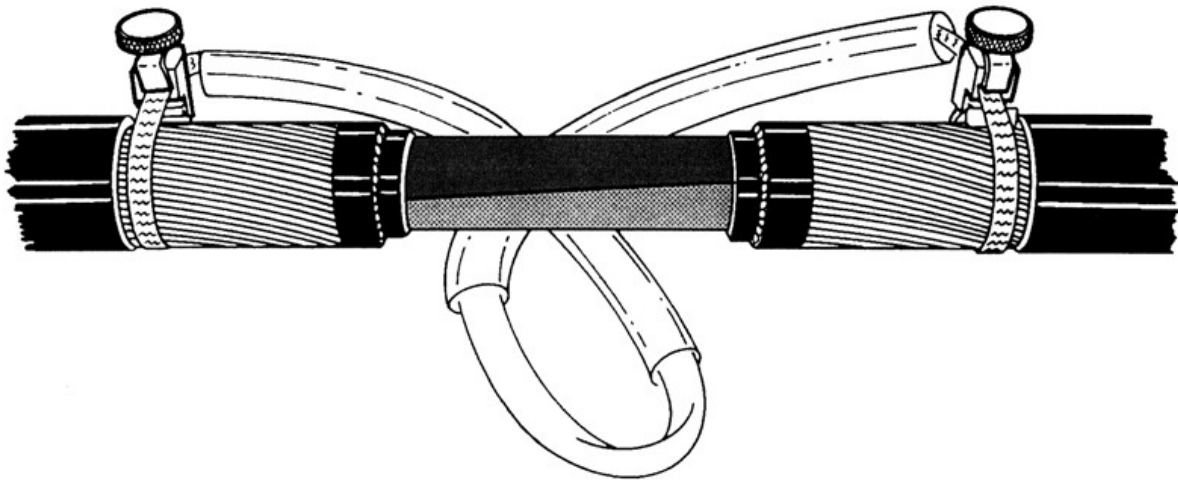

3. At this stage, make the phase core connections in accordance with the jointing instructions.

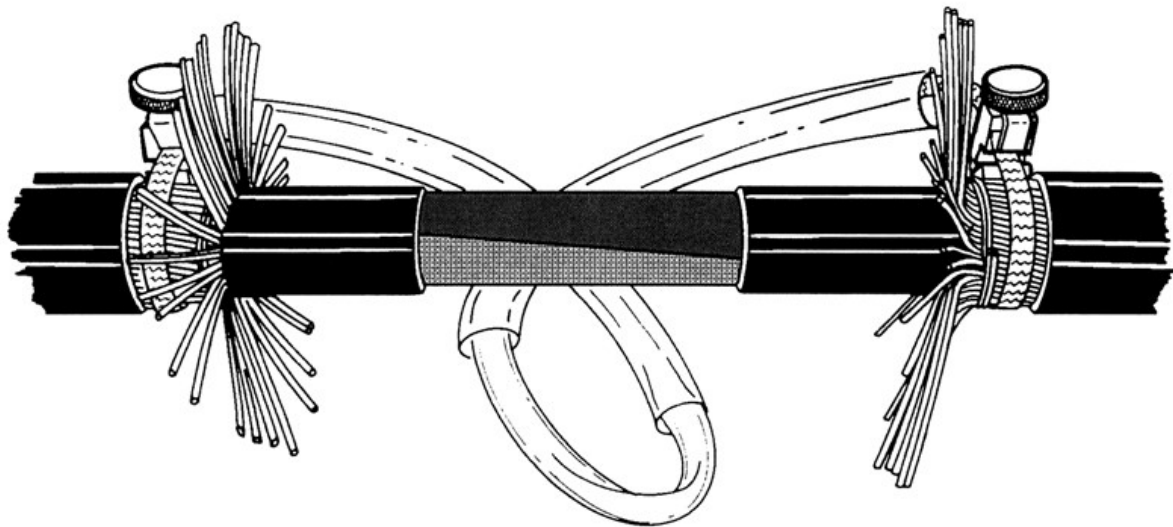

4. Apply a wire binder adjacent to the continuity connector to avoid disturbing the T.C.C. and splay the armour wires to expose the underarmour bedding.

AB Connectors

Illustrations—Typical Assembly Procedure

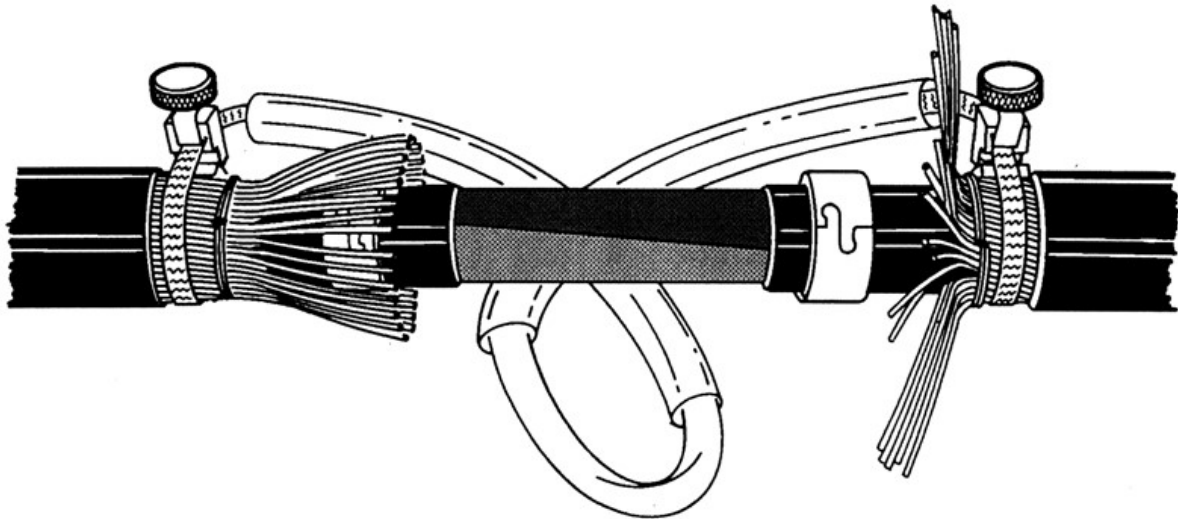

5. Place the split compression rings over the armour bedding, where necessary building up the bedding with insulation tape until a snug fit is achieved. Do not wrap tape over the compression rings. With the rings in place, bend the armour wires back over the rings, securing with a binder wire if needed.

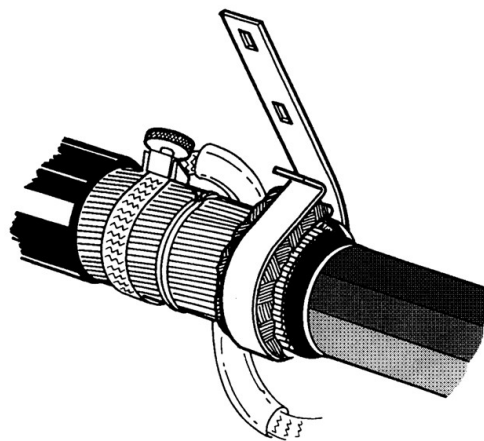

6. Pre-form the tension strap and place loosely in position around the armour wires with the hooked end towards the side from which the work is proceeding. Slide the tinned copper braid between the armour and the tension strap with the free ends uppermost.

When using the worm-drive clip system the clip is passed around the cable armour at this stage, the end of the cross bond being placed between the clip and the bedding braid, the clip then being fully tightened. Fixing when using this system is thus completed.

AB Connectors

Illustrations—Typical Assembly Procedure

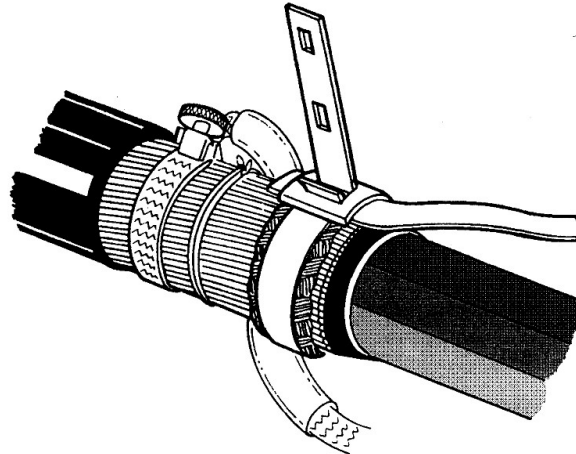

7. Fit the tinned copper strip(s) over the slotted end of the tension strap. Repeat this procedure with the buckle, and engage in the hooked end.

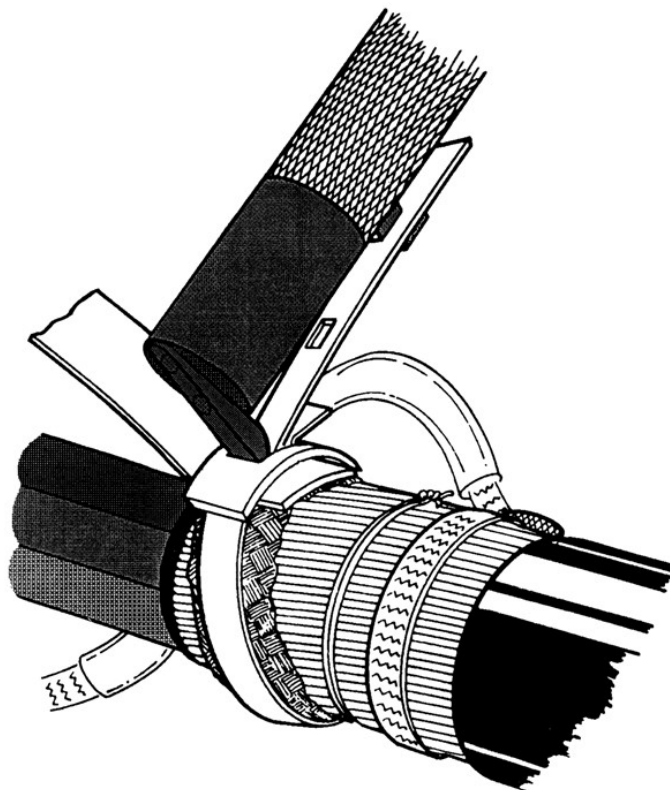

8. Engage the heel of the tension tool in the slot in the buckle as shown.

AB Connectors

Illustrations—Typical Assembly Procedure

9. Adjust the hook on the side of the tension tool until it can be engaged in the slot in the tension strap. Having applied initial tension with the tool dress down the hooked end of the strap with a hammer. Apply further tension with the tool, checking that the hooked end is not disturbed.

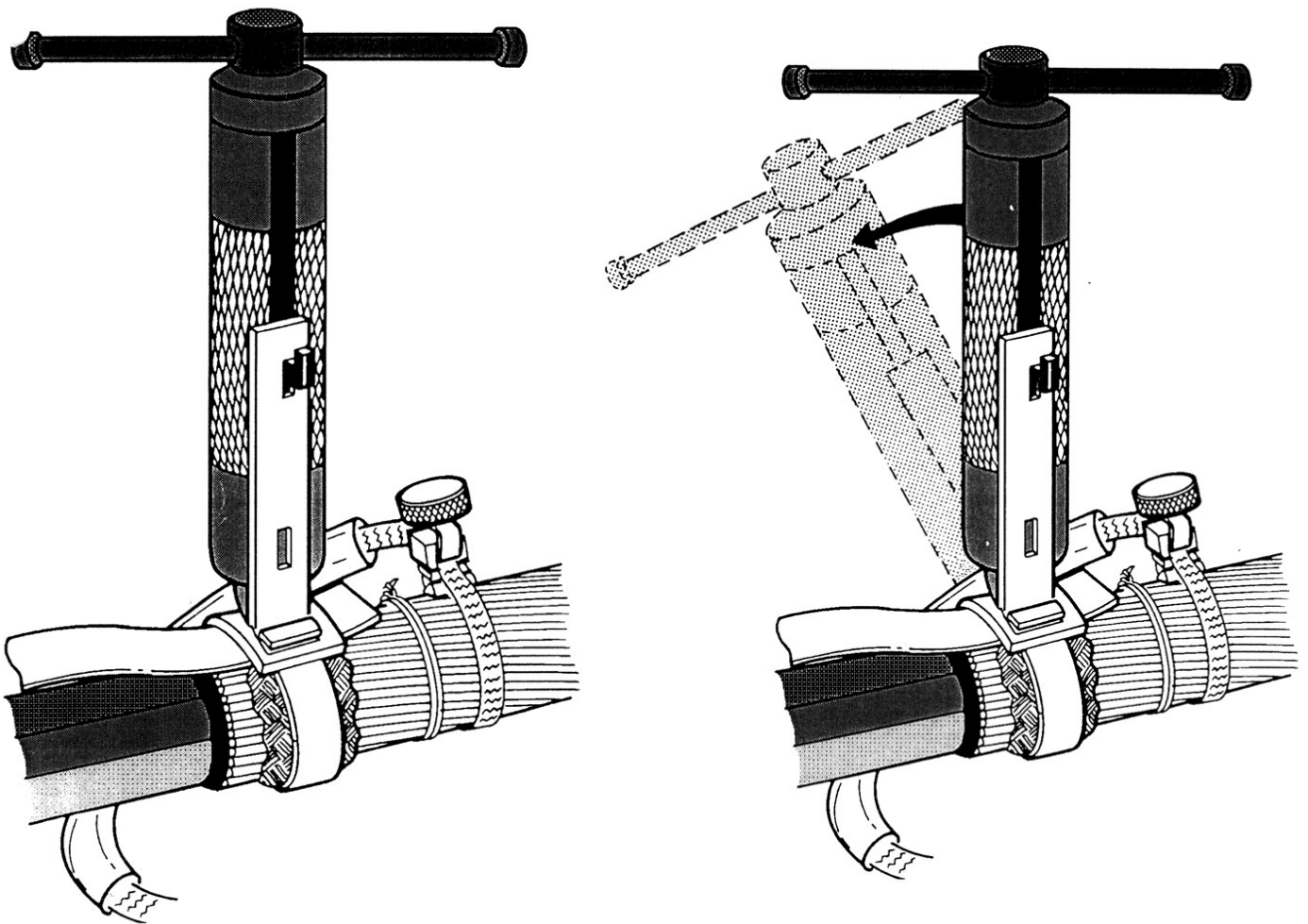

10. When sufficient tension has been applied and the whole assembly is firmly in position lock the strap against the buckle by easing the tool in the direction indicated by the arrow, thus putting a 'set' in the strap. Release the tension and disengaging the tool.

AB Connectors

Illustrations—Typical Assembly Procedure

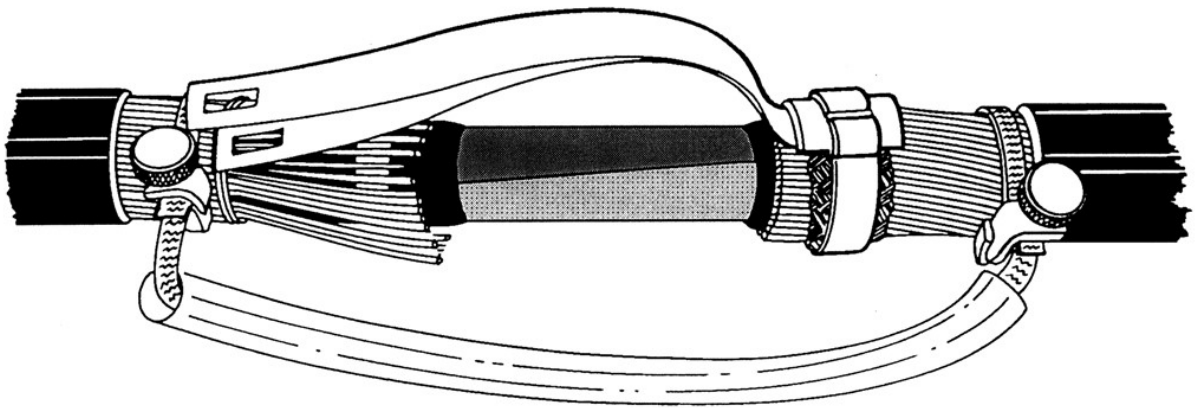

11. Complete the 'set' in the strap and cut off the surplus length. Dress down both ends of the strap to establish intimate contact with the buckle. The procedure from step 6 onwards should now be repeated at the opposite end of the joint to secure the other end of the bond.

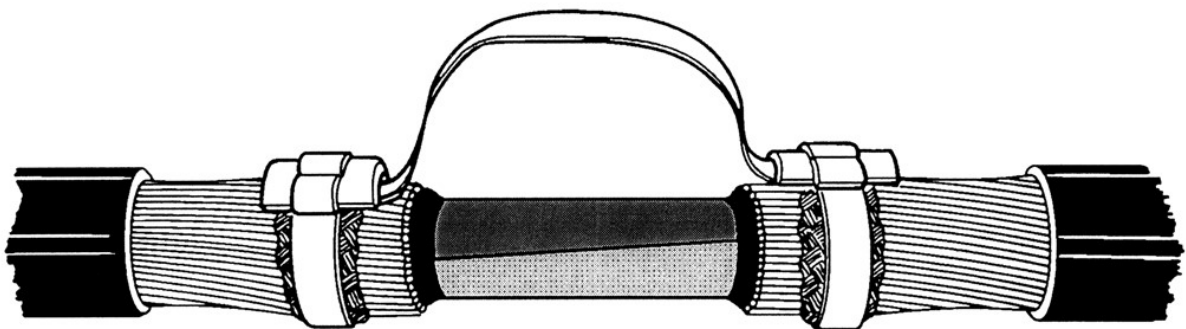

12. After completion of both ends the temporary connector may be removed.

AB Connectors

Sweated or Plumbed Connections

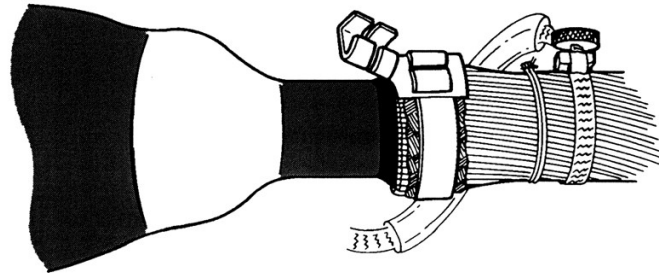

13. For situations involving lead sleeved joints there is a range of buckles available for use with the Hepworth tension strap system that enable various types of cross-bonds to be used.

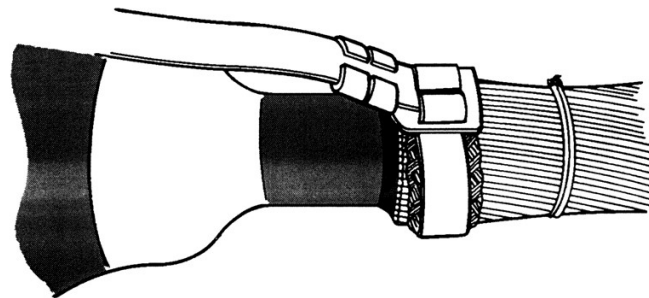

14. The copper bonding strip is inserted in the buckle, the claws of which are then closed to hold the strip on position. It is desirable that the copper strip should extend right through the buckle to butt up against the ends of the tension strap. When different types of cross bonding conductors are to be used, ie. cable or braid, alternative buckles can be provided.

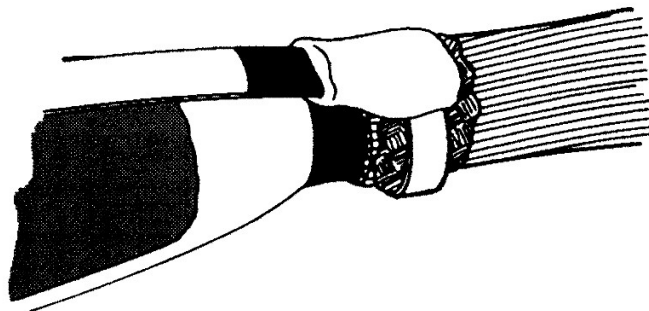

15. With the cross-bonds securely assembled in place, any necessary additional plumbing may be carried out in accordance with the relevant jointing instructions.

AB Connectors

Typical Completed Connections

Tension Strap System

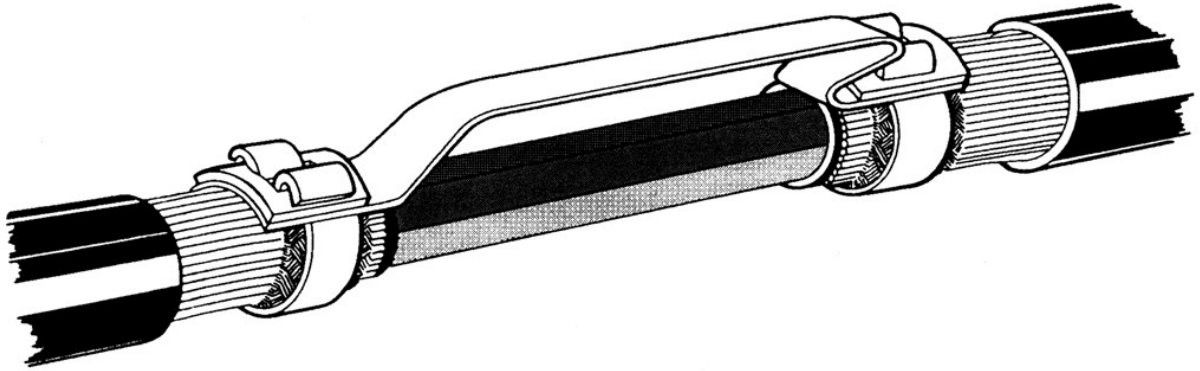

Tension Strap System—Plumbed

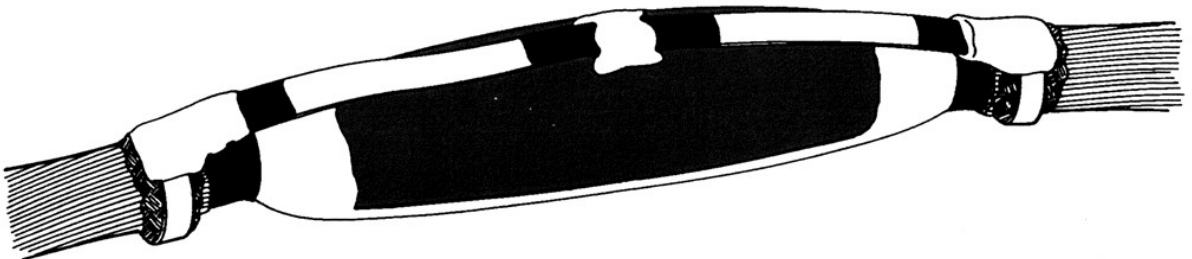

Worm Drive Clip System

